



Technische Daten

			ex2-14	ex2-21	ex2-40	dK4 21-60	dK4 21-80	dK4 40-80	dK4 40-100	dK4 40-200
			12/24V	12/24V	12/24V	12/24V	12/24V	12/24V	12/24V	24V
Trinkwasserleistung in l/h*	Salz- gehalt g/l	Temp. °C								
Standard 1	32	25	12	20	30	60	80	75	125/145	210
Standard 2	35	25	10	17	27	55	75	70	120/140	170
Ostsee, Schwarzes Meer	15	15	20	27	37	95	115	115	180/210	290
Mittelmeer	37	18	9	15	25	50	60	55	95/115	160
Atlantik	35	20	10	17	27	55	70	65	105/120	170
Pazifik, Ind.Ozean	34	22	10	17	27	55	75	70	115/125	180
Rotes Meer	42	25	9	14	24	40	55	50	80/85	120
Gewicht (kg)			17	18	19	42	48	67	67	67
Geräuschpegel dB(A)			62	62	62	66/68	66/68	66/68	66/68	68
Preise in € ab inkl. 19% MwSt.			3.900,-	4.200,-	4.600,-	8.300,-	8.900,-	9.900,-	11.500,-	12.500,-

*Die Leistungswerte sind stark abhängig von Salzgehalt und Temperatur des Rohwassers. Ausserdem können die Leistungswerte abhängig von der verwendeten Membrane um +/-15% schwanken (gem. Angaben des Membranherstellers).



Abmessungen

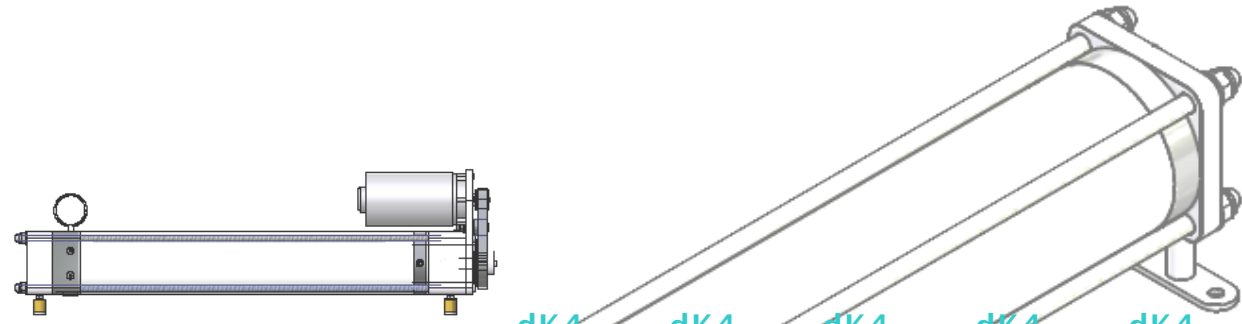

Dimensionen Kompaktanlagen:

Länge (mm)
Breite (mm)
Höhe (mm)
Gewicht (kg)

	ex2-14	ex2-21	ex2-40	dK4 21-60	dK4 21-80	dK4 40-80	dK4 40-100	dK4 40-200
Länge (mm)	590	770	1250	1200	1200	1650	1650	1650
Breite (mm)	200	200	200	380	380	380	380	380
Höhe (mm)	200	200	200	250	250	250	250	250
Gewicht (kg)	17	18	19	47	47	67	67	67

Dimensionen Modulanlagen:

Länge Pumpe (mm)
Breite Pumpe (mm)
Höhe Pumpe (mm)
Länge Druckrohr (mm)
Breite Druckrohr (mm)
Höhe Druckrohr (mm)

Länge Pumpe (mm)	380	380	380	380	380
Breite Pumpe (mm)	380	380	380	380	380
Höhe Pumpe (mm)	250	250	250	250	250
Länge Druckrohr (mm)	770	770	1250	1250	1250
Breite Druckrohr (mm)	170	170	170	170	170
Höhe Druckrohr (mm)	230	230	230	230	230

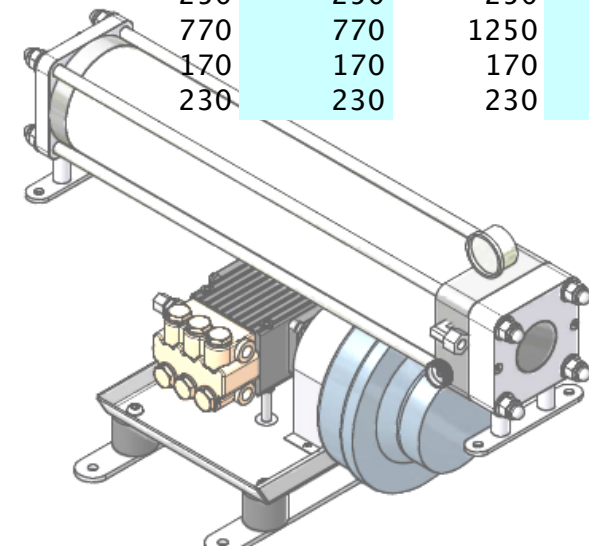
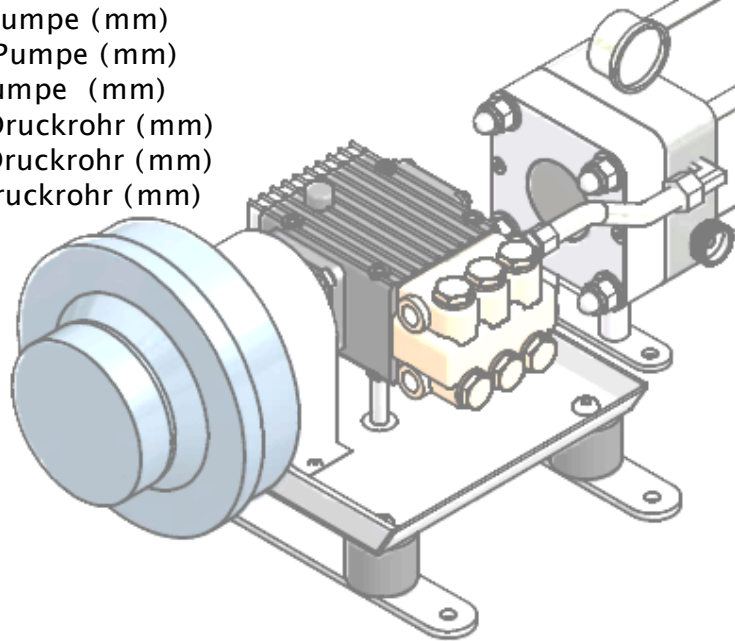



H2O-FACTORY GmbH & Co. KG
Ferdinand-Porsche-Str. 5/1
D-79211 Denzlingen

Tel.: +49-7666 88 20 027 Fax:
+49-7666 88 20 227 Email:
web@h2o-factory.com

www.h2o-factory.com